

REVISIONS						
ZONE	REV	DESCRIPTION	DATE	BY	CHK	APP'D

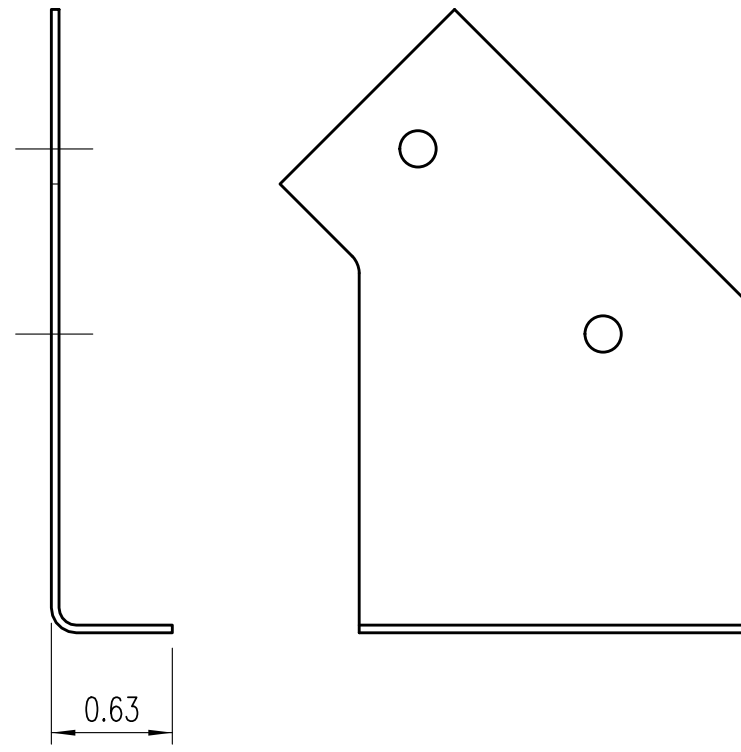
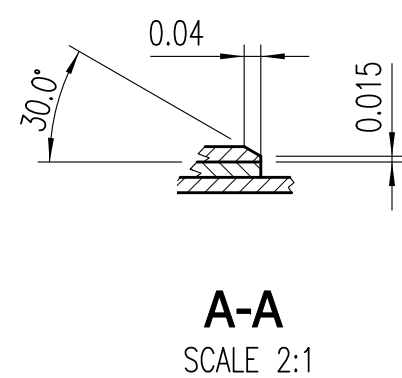
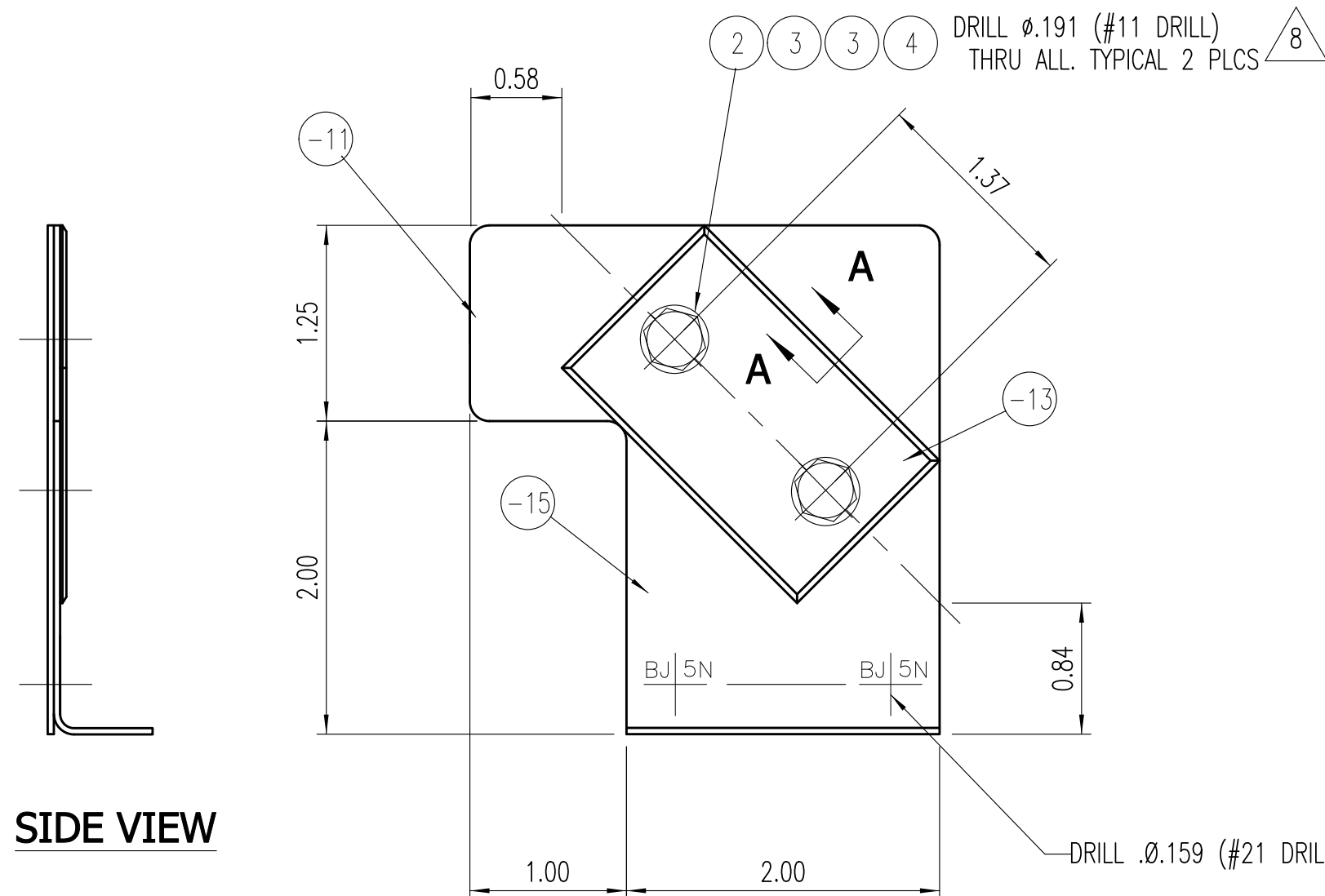

-1 ASSEMBLY
PLAN VIEW

-15 PROFILE DETAIL

NOTES:

- UNLESS NOTED OTHERWISE, ALL BEND RADII TO BE .125
- REFER TO NAS 523 FASTENER CODE FOR FASTENER CALL OUT INFORMATION. ADJUST FASTENER LENGTHS TO SUIT.
- FORMING AND ASSEMBLY IN ACCORDANCE WITH AC43.13 IB & 2B. NO SCUFFS PERMITTED MORE THAN ± 0.001 INCH (± 0.025mm) IN DEPTH.
- NO SCRATCHES PERMITTED. DO NOT TREAT OR FINISH
- MAINTAIN 2D ED AND 4D TO 6D SPACING. SPACE COUNT EQUALLY BETWEEN END FASTENERS.
- UNLESS NOTED OR SHOWN OTHERWISE ALL INSIDE AND OUTSIDE CORNER RADII TO BE 0.125
- TRIPLER PROFILE TO MATCH OUTLINE OF -11 AND -13 DOUBLER.
- SAFETY FASTENERS AS MAY BE REQUIRED, PER AC 4313, 1B & 2B

ZONE	REV	DESCRIPTION	DATE	BY	CHK	APP'D
2	4	AN310-3				
4	3	AN960PD-10				
2	2	AN3H-4				
AR	1	MS20470AD5-AR				
1	-15	ATG-029-15				
1	-13	ATG-029-13				
1	-11	ATG-029-11				
		ATG-029-1				

ZONE	SHEET	ITEM #	PART NUMBER	DESCRIPTION	MAT'L/MANUF.	SPECIFICATION	FSCM	H.T.
-1								

BJ = MS20470AD												
BASIC CODES												
<table border="0"> <tr> <td>BASIC CODE</td> <td>DASH NO. FOR DIA N=MFD HEAD NEAR SIDE F=MFD FAR SIDE</td> </tr> <tr> <td>C = COUNTERSUNK</td> <td></td> </tr> <tr> <td>D = DIMPLED</td> <td></td> </tr> <tr> <td># = SHEETS AFFECTED</td> <td></td> </tr> <tr> <td>1st LINE = MANU. HEAD</td> <td>DASH NO. FOR LENGTH W=SPOTWELD OPTIONAL</td> </tr> <tr> <td>2nd LINE = UPSET END</td> <td>EXISTING</td> </tr> </table>	BASIC CODE	DASH NO. FOR DIA N=MFD HEAD NEAR SIDE F=MFD FAR SIDE	C = COUNTERSUNK		D = DIMPLED		# = SHEETS AFFECTED		1st LINE = MANU. HEAD	DASH NO. FOR LENGTH W=SPOTWELD OPTIONAL	2nd LINE = UPSET END	EXISTING
BASIC CODE	DASH NO. FOR DIA N=MFD HEAD NEAR SIDE F=MFD FAR SIDE											
C = COUNTERSUNK												
D = DIMPLED												
# = SHEETS AFFECTED												
1st LINE = MANU. HEAD	DASH NO. FOR LENGTH W=SPOTWELD OPTIONAL											
2nd LINE = UPSET END	EXISTING											
NAS 523 FASTENER CODE												

GENERAL REQUIREMENTS—UNLESS OTHERWISE SPECIFIED		DRAWN	AUG 24/20	P. WATSON
1. DO NOT SCALE DRAWING		CHECKED		
2. DIMENSIONS ARE IN INCHES		STRUCTURES		
3. REMOVE SHARP EDGES AND DEBURR.		AVIONICS		
4. DIMENSIONS APPLY BEFORE SURFACE FINISH.		SYSTEMS		
5. ZONE CALLOUT: SHEET ZONE		APPROVED		
6. THIRD ANGLE PROJECTION		DATE		SIGNATURE
		PROPRIETARY TO MY ATG Inc. DISCLOSURE, REPRODUCTION OR USE REQUIRES PERMISSION IN WRITING FROM MY ATG Inc.		

MY ATG Inc.
LAKE COUNTRY, BRITISH COLUMBIA, CANADA

DRAWING TITLE
AERO SKILLS FROM HOME SENIOR

SIZE	FSCM NO.	DWG NO.	REV
C		ATG-029	NC

SCALE 1:1 SHEET 1 OF 1